

■ Mast Specifications of 1.5/1.8T Mini Electric Forklift (3-Fulcrum, AC motor System)

2-Stage High-visibility Mast

Mast Model	Max Lift Height	Lifting Capacity at 500mm load center		Overall Mast Height		Free lift height		Mast Angle
		1.5T	1.8T	1.5T-1.8T		1.5T-1.8T		1.5T-1.8T
		3-Fulcrums		Lowered	Extended With backrest	without backrest	With Backrest	Front/Rear
	Mm	Kg	Kg	Mm	Mm	Mm	Mm	( ° )
M200	2000	1500	1750	1745	3445	100	100	5/7
M250	2500	1500	1750	1845	3645	100	100	5/7
M300	3000	1500	1750	1980	3945	100	100	5/7
M330	3300	1500	1750	2145	4245	100	100	5/7
M350	3500	1500	1750	2245	4445	100	100	5/7
M360	3600	1450	1650	2295	4545	100	100	5/7
M400	4000	1400	1600	2545	4945	100	100	3/5
M425	4250	1350	1500	2710	5245	100	100	3/5
M450	4500	1300	1400	2820	5445	100	100	3/5

2-Stage Full Free Lift Mast

Mast Model	Max Lift Height	Lifting Capacity at 500mm load center		Overall Mast Height		Free lift height		Mast Angle
		1.5T	1.8T	1.5T-1.8T		1.5T-1.8T		1.5T-1.8T
		3-Fulcrums		Lowered	Extended With backrest	without backrest	With Backrest	Front/Rear
	Mm	Kg	Kg	Mm	Mm	Mm	Mm	( ° )
2FFM200	2000	1500	1750	1745	3445	985	525	5/7
2FFM250	2500	1500	1750	1845	3645	1205	735	5/7
2FFM300	3000	1500	1750	1980	3945	1455	985	5/7
2FFM330	3300	1500	1750	2145	4245	1605	1135	5/7
2FFM350	3500	1500	1750	2245	4445	1705	1235	5/7
2FFM360	3600	1450	1650	2295	4545	1755	1285	5/7
2FFM400	4000	1400	1600	2545	4945	2005	1535	3/5
2FFM425	4250	1350	1500	2710	5245	2155	1685	3/5
2FFM450	4500	1300	1400	2820	5445	2255	1785	3/5

3-Stage Full Free Lift Mast

Mast Model	Max Lift Height	Lifting Capacity at 500mm load center		Overall Mast Height		Free lift height		Mast Angle
		1.5T	1.8T	1.5T-1.8T		1.5T-1.8T		1.5T-1.8T
		3-Fulcrums		Lowered	Extended With backrest	without backrest	With Backrest	Front/Rear
	Mm	Kg	Kg	Mm	Mm	Mm	Mm	( ° )
3FFM435	4350	1280	1400	2065	5390	1415	1100	3/5
3FFM450	4500	1250	1400	2115	5540	1480	1170	3/5
3FFM470	4700	1250	1300	2185	5740	1580	1270	3/5
3FFM500	5000	1100	1200	2315	6040	1645	1340	3/5
3FFM540	5400	900	1000	2440	6440	1815	1500	3/5
3FFM550	5500	750	850	2465	6540	1815	1500	3/5
3FFM600	6000	500	650	2665	7040	2010	1670	3/5

Note: 1, All those data is the standard work data, and can be changed due to the work influence.  
2, With side-shift, load capacity subtract 200kg/440Lbs.

Specifications and design are subject to change without prior notice. Machines shown may include optional equipment.



CPDS Series

Three-wheel Electric Forklift

ISO9001  
CE



SINOLIFT MATERIAL HANDLING EQUIPMENT CORP.

ADD: 618 Xile Road, Nanhui, Shanghai, China 201300

TEL: +86 21 68014500 /+86 21 58003681

FAX: +86 21 68014262 /+86 21 68038190

EMAIL: [info@sinolift.com](mailto:info@sinolift.com)

WEB: [www.sinolift.com](http://www.sinolift.com)





### 1.5/1.8T Three-wheel AC Electric Forklift Truck

- Adopting man-machine engineering theory, integrating advanced design ideology, the CPDS forklift is a type of safe, environmental protecting, efficient battery forklifts, geared to intermediate and senior customers.
- Elastic to operate, pleasing to the eyes, and energy saving, is the ideal choice to carry out stevedoring and stacking in interior narrow space.
- Wholly integrated frame: its intensity and safety are high.
- Using imported well-know brand, all the curcial components passed strict test, guaranteeing stable working.
- All the electro circuits possess overheat protection, reverse connection protection and anti-short circuit functation, Besides, waterproof and dustproof function have been enhanced.
- By using on-off technique to cut off the electricity when the drive operate the forklift incorrectly or leave the seat.
- Comparing with DC motors, the AC motors provide operator with more smooth, sensitive and quicker response of operation.
- No more maintenance for AC motors, which can extend the service life of the motors. AC technology is better suited for heavy-duty applications. the use of current is optimised and AC motors are brushless, and can be well protected against the water and dust, Roll-back is almost eliminated and higher travel speeds are attainable.

### Features:

#### Efficiency, Reliability and safety, Easy to maintenance and service

- High visibility masts constructed of German Steel
- Heavy duty and highly efficient motors
- The new multi-functional LCD dash board provides more information for operator
- Fully hydrostatic power steering and tilt steering wheel
- Strong unibody construction



#### Dynamical System (Drive)

The two energy efficient and noise optimised three-phase drive units on the CPDS act on the front wheels, High traction power and driving dynamics, even on uneven ground or when climbing ramps, ensure a high turnround of goods. A special feature in this is the uniformly strong development of the power from a standstill up to maximum speed. Thus for instance there is always maximum power available at kerbs or when pushing pallets. The maintenance-free, efficiency-optimised three-phase drive guarantees a long battery operating life. provide the truck with excellent acceleration quality and gredability. Thanks to complete enclosure the whole drive is protected against the ingress of damaging dust and water spray, so that even applications in the worst conditions are no problem.



#### S.M.E AC Controller and Logic Control Block (Italy)

The truck adopts MOSFET travel & lift controller to control its working more concisely. The truck possesses advantageous serviceability, including regenerative braking,plug braking,antislip on a slope other functions. the controller is installed in enclosed frame, preventing the electric controlling and hydraulic components from pollution and waterspray. The logic control block is the heart of ITC, the intelligent system able to control and monitor of all lift truck functions. It's an electronic board designed to drive up to 4 AC motors, developed and manufactured by S.M.E with the support of the last technology.



#### High Capacity Battery

Because you open and close the battery cover for daily checkup, access of battery cover is improved by using gas-spring with lock function. Quick and easy battery change due to tilt-open cab module.



#### Chassis, Hydraulics and Brakes

A fully enclosed chassis frame house the drive motors. The hydraulic and drive compnents are protected against dirt and water. The CPDS series three-wheel truck has three independent braking systems:  
 Regenerative braking system  
 Hydraulic wet disc brake system  
 Toggle-type parking brake

### CPDS Series 1.5T/1.8T Three-wheel AC Electric Forklift Specifications

		SINOLIFT					
		CPDS15	CPDS18				
Characteristics	Manufacturer						
	Model						
	Rated capacity	kg	1500	1750			
	Load center	mm	500	500			
	Power type		Battery	Battery			
	Tyres		Super elastic	Super elastic			
	No. of tyres (front/rear)		2/2	2/2			
	Lift height	B	mm	3000	3000		
	Free lift height	E	mm	130	130		
	Fork size	NxUxL	mm	35×100×920	35×120×920		
Dimensions	Upright tilt (forward/backward)		K/T	deg	5/7	5/7	
	Overall dimensions	Length to fork face			mm	2780	2830
		Length to fork face(without fork)		J	mm	1860	1910
		Wheel width			mm	1050	1050
		Overall width		W	mm	1070	1070
		Height with mast lowered		C	mm	1980	1980
		Height with mast extended		A	mm	3945	3945
	Height of overhead guard		D	mm	1990	1990	
	Turning radius (outside)		P	mm	1500	1500	
	Front overhang		G	mm	360	360	
Right-angle store aisle (pallet 800x1200,1000x1200)		RASA	mm	2860/3060	2910/3110		
Performance	Travel speed (with/without load)			km/h	13.2/14.3	12.8/14	
	Lifting speed (with/without load)			mm/sec	300/470	300/470	
	Lowering speed (with load)			mm/sec	450	450	
	Max. pulling force			KN	14.84	13.08	
	Grade ability (with load)			%	20	19	
Weight	Service mass (including battery)			kg	3100	3260	
	Load per axle	Full load (front/rear)		kg	4020/560	4300/640	
		Without load (front/rear)		kg	1540/1540	1480/1740	
Chassis	Tyres size		Front		18×7-8 PR	18×7-8 PR	
			Rear		16×6-8 PR	16×6-8 PR	
	Wheel base		F	mm	1295	1295	
	Wheel tread		Front	Q	mm	895	895
			Rear	S	mm	205	205
	Ground clearance (full load/without load)		Mast	H	mm	80/85	75/85
			Frame	M	mm	100/110	100/110
Service brake					Hydraulic	Hydraulic	
Power unit	Battery		Type		Ironclad plates	Ironclad plates	
			Voltage/capacity	V/Ah	48/505	48/505	
			Mass	kg	850	850	
	Electric motor		Traction, power		kw	6.5×2	6.5×2
Lift, power			kw	12	12		

- Special lifting height available.
- Attachment available.
- The specification in the table are for standard models only, All specifications indicated are subject to a variation of ± 15%, and may be further affected by operation conditions, optional fitments and accessories. Critical specification should be confirmed before placement of order.Specification are subject to change without notice, for further information ,please contact us.

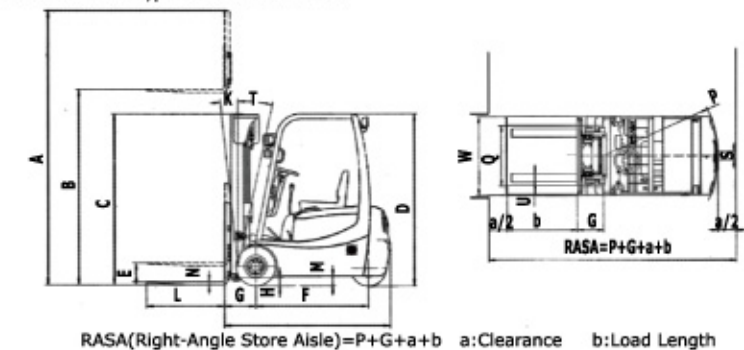
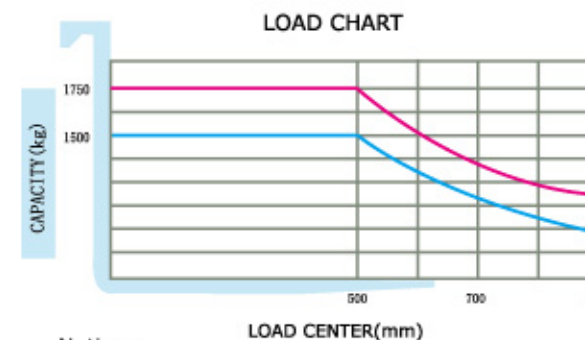

#### Notice:

Vertical axle stands for load capacity while horizontal axle stands for load center,load center is the distance counted from the front of the fork,The base point of the standard load is the center point of the cubic with the same 1000mm dimension in length,width and height,The load capacity should be down,if mask fits forward,using non-standard forks or loading goods with extra width,Please the different load capacity between different load centers according to load chart.